

HIGH VOLTAGE DC-DC CONVERTER USING A SERIES STACKED TOPOLOGY

Author: P.D. van Rhyn, Co Author: Prof. H. du T. Mouton

Power Electronics Group (PEG)
University of the Stellenbosch
Tel / Fax: 021 808-3220
e-Mail: nielvr@sun.ac.za

Abstract: As part of constructing a high power DC-AC inverter, a series stacked DC-DC converter is analysed and simulated. The stack consists of a number of isolated, full-bridge topology converters. The “lower” input voltage rating of each individual converter is combined to form a new converter which has a higher input voltage rating.

The converter will be used to charge a large battery bank as well as supplying power to a constant power absorbing load. It will have to operate in either constant current mode or constant voltage mode, depending on the state of charge of the battery bank. Peak current mode control is implemented to give this functionality to the converter. The series stack topology also allows interleaved switching which reduces the size of filter components.

This paper covers the basic concept behind this series stacked topology and some control aspects and considerations, as well as simulations of converter.

1 INTRODUCTION

Even though switch voltage ratings have greatly improved in recent years, it is still necessary in higher voltage applications to connect switches in series to meet the high voltage demands of some systems [1]. These high voltage demands could also be met by connecting converters in series or to make use of one of the multilevel topologies [2, 3]. These topologies could be the flying capacitor or the diode clamp topology. In general these multilevel topologies are used in DC-AC or AC-AC inverters. The main advantage of these topologies is their harmonic reduction property. By using an appropriate modulation technique (like a square wave reference) in these topologies it could be possible to use these topologies in DC-DC conversion.

The scope of this paper is to investigate the use of a series stack of converters in order to create a high voltage DC-DC converter. This converter will form part of an industrial power supply which inverts a DC

supply of between 2 and 4kV into a 230V AC output. The output will be three phase and the inverter will have a power rating of 50kVA. The inverter will consist of two parts as shown in figure 1.

The supply voltage will first be converted to 110V DC by a DC-DC converter and then inverted to a three-phase output voltage.

The reason for this is that a 110V battery bank is standard equipment in every Spoornet substation, where the converter will be installed. The battery bank will be used as a backup supply for the DC-AC converter if the system input supply is out. The function of the DC-DC converter is to charge the battery bank and supply power to the DC-AC converter if a load is present.

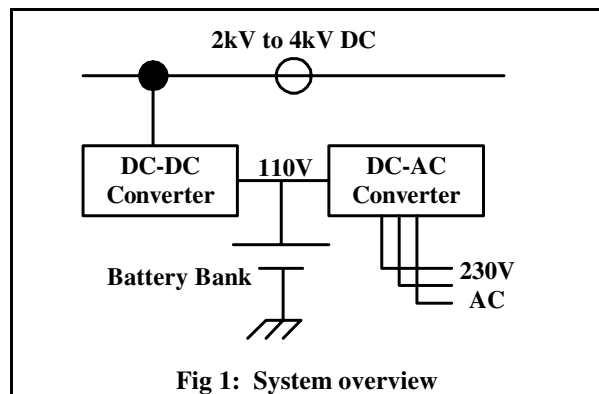

Section 2 of this paper looks at the converter topology while section 3 covers some control aspects. Section 4 will look at simulation and results obtained from these simulations. In the last part of this paper conclusions are made and possible future work is discussed.

2 THE CONVERTER TOPOLOGY

The output voltage of this converter will be lower than the input voltage. It is thus a “buck” type converter. The individual converters that form the main converter could also then be buck type converters but this is not essential as a transformer will be used for electrical isolation. To decide which

of the many buck derived topologies to use for the individual converter topology, the following factors are considered.

- As a design specification, the converter will have to be electrically isolated.
- The individual converters are also high power converters (12.5kW each).
- Operation in constant current mode and constant voltage mode are essential.

The half-bridge and the full-bridge topologies are both suitable for handling the required power and suited for transformer implementation. The deciding factor is that peak current control will have to be implemented to enable constant current and constant voltage control in the converter. The half-bridge topology is not suited for current mode control as slight component and duty ratio mismatches could cause a bulk capacitor unbalance [5]. Another concern of the half-bridge topology is large ripple current through the bulk capacitors. The full-bridge topology is chosen and will be used as individual converter topology. One concern of using the full-bridge topology is that, although current mode control is used, the transformer core might still saturate. This is because inductor current is measured, on the secondary side of the transformer, and not the transistor-emitter current on the primary side of the transformer [5].

The converter is shown in figure 2. The topology has its origin from the “Input-Series-Output-Parallel-Connected” converter proposed by Kim [6]. This idea of putting the inputs in series and the outputs in parallel is used.

Figure 2 shows a simplified part of the converter. The individual full-bridge converters are connected in series and the outputs are paralleled.

This connection holds the following advantages:

- If n converters are connected in series, the switch voltage rating can be reduced to $\frac{V_{IN}}{n}$, as long as the bus capacitors are balanced.
- The maximum voltage rating of all the semiconductors is reduced.
- The output current is shared among the converters.

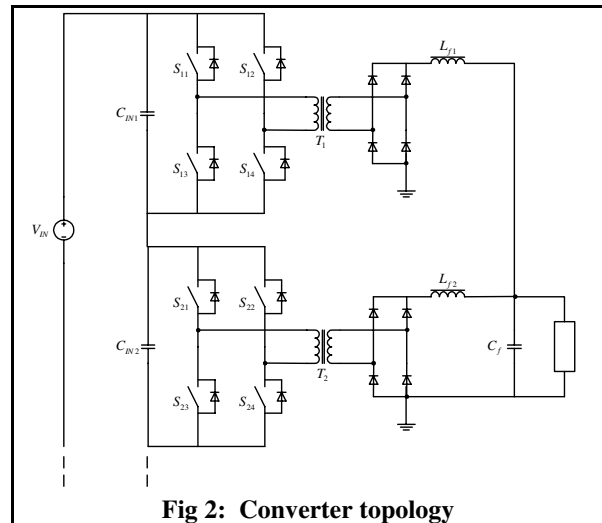

Fig 2: Converter topology

The disadvantages of this topology are:

- There are a larger number of semiconductors, which increases the chance of system failure.
- The switch voltage rating may be exceeded if the bulk capacitors do not balance.

3 CONTROL OF THE CONVERTER

Controlling the converter is an essential part of the eventual successful operation of the converter. The converter will be exposed to change in input voltage, change in load and, as mentioned in section 2, will have to operate in constant current mode as well as constant voltage mode. Last mentioned will depend on the state of charge of the battery bank.

Peak current mode control [5] will be implemented to control the converter. In peak current control the switch or inductor current is measured and compared to a reference value. The switch (or switches, depending on the converter topology) is turned on while the measured current is less than the reference and then turned off as it reaches the reference. Normally a clock pulse will then turn the switches on again and the cycle repeats itself. In this converter bipolar voltage switching is used [7]. This means that switches S_{11} and S_{14} , and switches S_{12} and S_{13} are switched together. The control signals of one converter's switch pairs are 180 degrees out of phase. To realise interleaved switching these signals are then shifted by $\frac{360^\circ}{n}$ (n is the number of converters in the stack) and used as control signals for the rest of the converters in the stack. This will ensure bulk capacitor balance [2].

$$T_1 = T_i + T_v \text{ and } T_2 = \frac{T_v}{1 + T_i}$$

The loop gains are also plotted using the bode-plot technique and used to verify system stability.

Figure 4(b) shows the control block diagram if the converter operates in constant current mode. The load current measured is added to C and used as a reference as explained earlier. This forms a new feedback loop which could cause instabilities if proper compensation is not implemented. The transfer function of duty cycle to load current is not known and thus a compensator could not be designed as in the constant voltage mode case. A low pass filter $G_{LP}(s)$ is implemented to eliminate sudden changes in reference which could cause instabilities.

The control method implemented uses one measured inductor current together with the output voltage reference to control the main converter. Another way of controlling the converter system is to control all the individual converters separately using the same controller discussed earlier. An additional “share” control loop could then be added to share the currents among the converters [9]. This control will unfortunately not guarantee capacitor balance. This problem could be solved by adding yet another control loop.

4 RESULTS FOR CONVERTER SIMULATION

The two modes of converter operation were simulated using Simplorer. The simulation was done for a scaled model of one tenth the voltage and current ratings of the converter to be built practically. The converter parameters are as follows.

Switching frequency	$f_s = 50\text{kHz}$
Input voltage	$200 < V_{in} < 400.$
Output voltage	$V_{out} = 13.4 \text{ V}$
Filter inductance	$L_f = 1 \text{ mH}$
Maximum output power	$P_{max} = 600\text{W}$
Filter capacitance	$C_f = 470\mu\text{F}$
Transformer winding ratio	$N = 2:1$
Number of converters in stack	$n = 4$

Interleaved switching was implemented in simulating the converter.

4.1 Constant voltage mode operation.

The first simulation was done to look at the step response of the converter in constant voltage mode. Figure 5 shows the output voltage and current (V_{out} , I_{out}), as well as one of the filter inductor

currents (I_{L1}). Note that, as we expect, the total output current is four times the inductor current. For this simulation the input voltage is fixed at 400V and the load resistor is equal to 1.34 Ohm (thus 10A output current).

The settling time appears to be good (less than 2ms). The current overshoot is high. To better this overshoot, the response could be made slower by decreasing the gain in the voltage loop or to make the compensator slower.

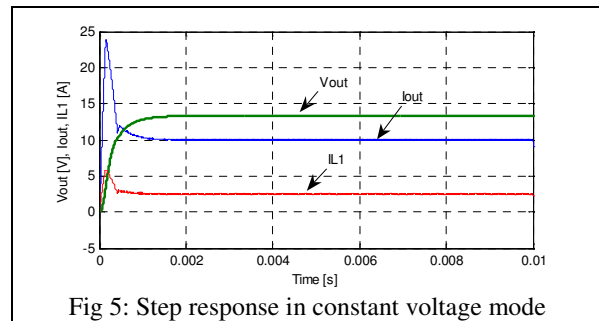

Fig 5: Step response in constant voltage mode

Figure 6 shows the inductor currents of the four converters. As expected for interleaved switching, the inductor currents are shifted by $5\mu\text{s}$ with respect to each other (corresponding to $\frac{360^\circ}{n \text{ conv. in stack}}$). The sum of these currents will form the total ripple current with n times the frequency. The amplitude of the ripple current will be less than $100/n\%$ of one inductor current, but could be less depending on the duty cycle.

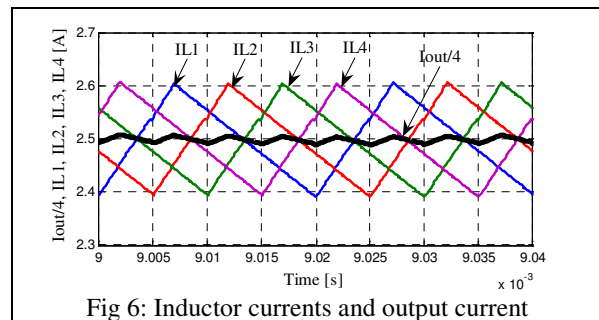

Fig 6: Inductor currents and output current

Figure 7 shows the capacitor voltages for a 300V input voltage. It is clear that they remain balanced at

$$\frac{300}{n} = 75\text{V}.$$

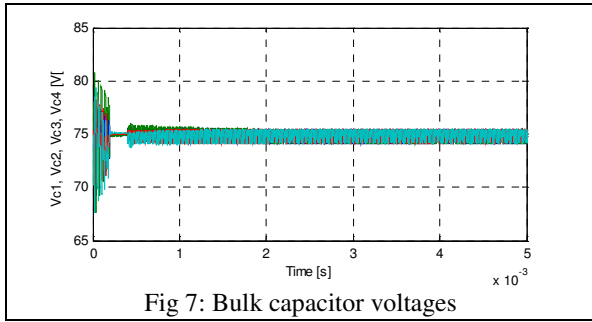

Fig 7: Bulk capacitor voltages

To see what effect component tolerances will have on the converter, components were randomly chosen and given a 10% tolerance. No significant differences were visible. Only a slight offset in one of the inductor currents (figure 8) was visible.

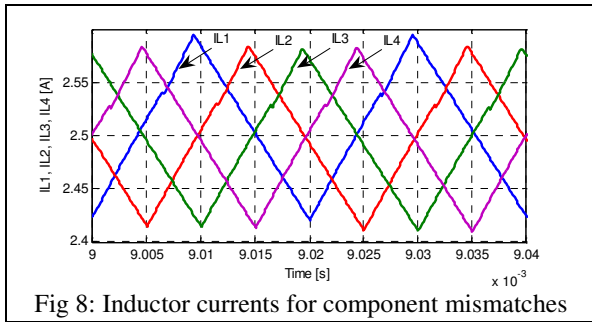

Fig 8: Inductor currents for component mismatches

Lastly the line and load regulation were simulated. Figure 9 shows the output voltage when the input voltage is stepped up from 200V to 400V. Good line regulation is visible as expected for current mode control.

Load regulation is also good. A load resistance step from 10 Ohm to 0.29 Ohm was simulated. The result is shown in figure 9. The output current step (1A to 45.4A) is shown as well as the output voltage which is regulated at 13.4V.

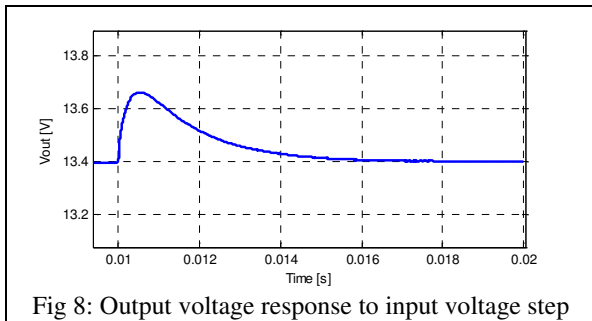

Fig 8: Output voltage response to input voltage step

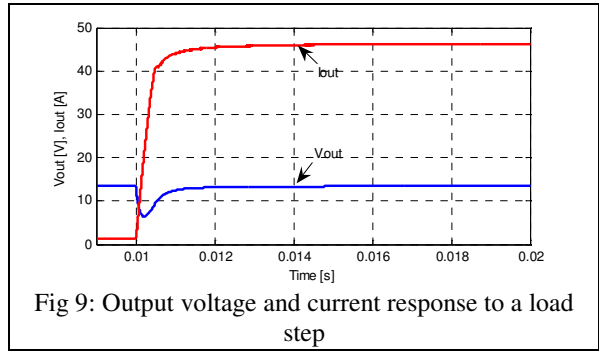

Fig 9: Output voltage and current response to a load step

4.2 Constant current mode operation.

The step response of the converter operating in constant current mode is shown in figure 10. This simulation is done with the battery bank disconnected from the output. The reason for this is that we only want to look at the response time of the constant current loop. The load voltage and current, one inductor current and battery current are shown. It is clear that the response time is much slower than in the voltage loop. This is because of the low pass filter implemented in the constant current loop. In this case it is only important that output voltage and output current settles and the exact values are not that important.

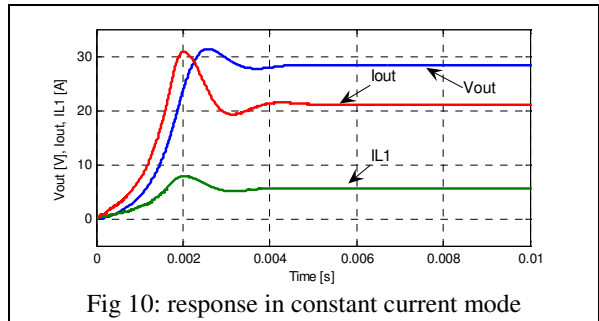

Fig 10: response in constant current mode

Figures 11 and 12 show the response of the converter to an input voltage step and a load step. In this simulation the battery bank (modelled by a constant voltage source in series with a resistor) is connected to the output. The battery bank is not fully charged and in the battery model, the voltage source is set to 12V.

It can be seen that the converter is stable when load current and input voltage steps occur, while charging the battery with a constant current.

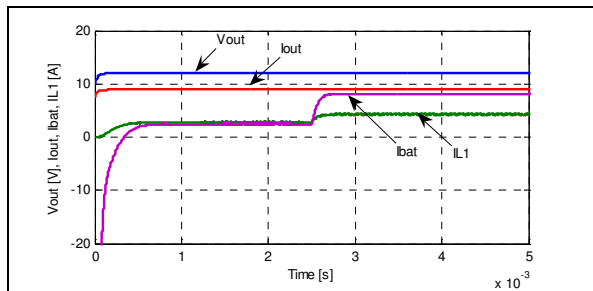

Fig 11: Response with step in input voltage.

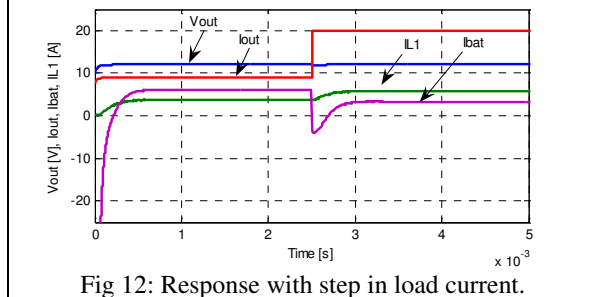

Fig 12: Response with step in load current.

As in constant voltage mode the bulk capacitors also balance, but takes longer to settle because of the slow responding low pass filter present in constant current mode. Figure 13 shows the voltage across the bulk capacitors.

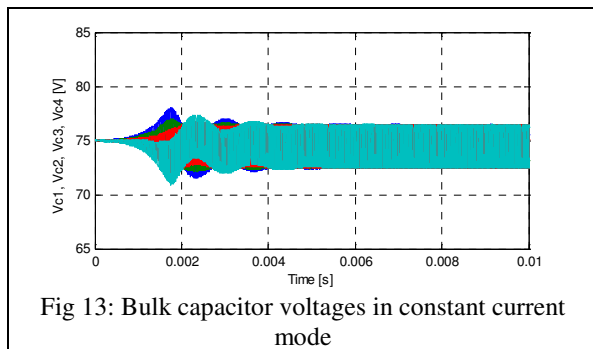

Fig 13: Bulk capacitor voltages in constant current mode

5 CONCLUSIONS

This paper explained the concept of stacking multiple converters in series to accommodate high input voltages. The converter operates in constant voltage and current modes. A control scheme is looked at to control the converter in these two modes. The system was simulated to ensure that the bulk capacitors balance, inductor currents share equally, voltage regulation is good in constant voltage mode and that the battery charge current is constant in constant current mode. The results obtained suggest that the system is stable under all operating modes and conditions.

Future work will look at the practical implementation of the system.

6 REFERENCES

- [1] Horowitz, Hill, "The art of electronics", Second edition, Cambridge university press, pp. 371-372.
- [2] H. du T. Mouton, "Analysis and synthesis of a 2 MVA series-stacked power-quality conditioner", PhD Thesis, University of Stellenbosch, Stellenbosch, South Africa, December 1999.
- [3] Peng, F. Z. (2001). "A generalized multilevel inverter topology with self voltage balancing." Industry Applications, IEEE Transactions on 37(2): 611-618.
- [4] Lload H. Dixon, Jr. "Current-Mode Control of Switching Power Supplies", <http://www.ti.com>, 2004
- [5] Mitchell, Mammano, "Designing Stable Control Loops", <http://www.ti.com>, 2004
- [6] Kim, J.-W., J.-S. Yon, et al. (2001). "Modeling, control, and design of input-series-output-parallel-connected converter for high-speed-train power system." Industrial Electronics, IEEE Transactions on 48(3): 536-544.
- [7] Mohan, Undeland, Robbins, "Power electronics", Second edition, Wiley, pp 322-328.
- [8] Ridley, R. B., B. H. Cho, et al. (1988). "Analysis and interpretation of loop gains of multiloop-controlled switching regulators [power supply circuits]." Power Electronics, IEEE Transactions on 3(4): 489-498.
- [9] Lin, C.-S. and C.-L. Chen (2000). "Single-wire current-share paralleling of current-mode-controlled DC power supplies." Industrial Electronics, IEEE Transactions on 47(4): 780-786.