

Service Brokering in IP Multimedia Subsystem

Asma Elmangosh¹, Majdi Ashibani¹, Neco Ventura², and Fathi Ben-Shatwan¹

¹Electrical Engineering Department
Higher Institute of Industry
P. Box 841, Misurata, Libya
{a-elmangosh, mashibani, fshatwan}@hii.edu.ly
²University of Cape Town
Rondebosch, South Africa
neco@crg.ee.uct.ac.za

□

Abstract— The IP Multimedia Subsystem (IMS) has been standardized as a Service Delivery Platform (SDP) positioned in the control layer of the Next Generation Network (NGN) infrastructure. To meet the diverse demands from NGN customers, it is effective to integrate different technologies, such as telecommunication, mobile, and Internet to enrich offered services. To integrate these domains the Service Oriented Architecture (SOA) concept developed for enterprise networks, can be applied into the IMS architecture. In this paper we overview the service control methods in IMS, discuss the concept of using a Service Broker (SB) to control and orchestrate service executions, and address some main issues of the integration of the SB component in the IMS architecture.

Keywords: NGN, IMS, SOA

I INTRODUCTION

The convergence of fixed and mobile telecommunications networks and applications, cable networks, as well as the Internet leads into a global all-IP based Next Generation Network (NGN). NGN is defined as a packet network in which transport elements such as switches and routers are logically and physically separated from the service/session control plane supporting multimedia services [1]. The key characteristics of NGN services are: a) ubiquitous, real-time, multi-media communications, b) more “personal intelligence” distributed throughout the network, c) more simplicity for users and personal service customization and management.

To enable such advanced services the NGN will have more distributed intelligence among network elements. This in contrast to conventional IP networks where intelligence is shifted to edges only. The NGNs, due to their flexibility provide an opportunity to rapidly develop new applications/services, which can lead to an evolution of user’s behavior. It is expected that there will be a huge increase in the demand for new, innovated multimedia services, such as

video streaming, online gaming, and video conferencing [2]. It is obvious that the success of such applications is related to the level of guaranteed Quality of Service (QoS) that the network providers could purvey to the users, in order to improve their Quality of Experience (QoE).

IP Multimedia Subsystem (IMS) was defined as core network overlay by 3GPP and has been adopted in many commercial networks, to provide a framework for enhanced and distributed service delivery over IP, independent of access technology [15]. The IMS acts as a platform for delivering any conceivable multimedia service and provides a generic architecture, which contains several common elements that could be shared among applications. As a result, applications can be efficiently developed and rapidly delivered to end users by sharing common elements/features such as user-profiles, billing, security, and negotiable QoS. IMS provides per-subscriber level of control of QoS as part of QoE. As the subscriber uses various composite services, the IMS ability to control QoE/QoS, becomes a huge differentiator for IMS over just uncontrolled access over the Internet.

The IMS Specifications do not define how advanced services should be provisioned, but do provide an interface which connects to the application layer. This is known as the IMS Service Control (ISC) interface and is based on Session Initiation Protocol (SIP) [8]. Offered services are not limited purely to SIP-based services since an operator is able to offer access to services based on the Customized Applications for Mobile network Enhanced Logic (CAMEL) Service Environment (CSE) and the Open Service Architecture (OSA) for its IMS subscribers [6]. Therefore, Applications Service (AS) is the term used generically to capture the behaviour of all types of servers implementing different technologies. Figure 1 depicts the simplified IMS architecture.

The IMS major role is acting as the launching point for the invocation of “services enablers” [3]. Service enablers provide reusable service capabilities (such as messaging, and presence information) to service developers in order to implement more sophisticated services (such as video conferencing). A key to meeting this role is the ability to deliver seamless combinations of different kind of services. This involves feature interaction management among combinations of

[□]The work presented in this paper is in result of the programme of collaboration research between the Higher Institute of Industry – Libya, and the University of Cape Town- South Africa.

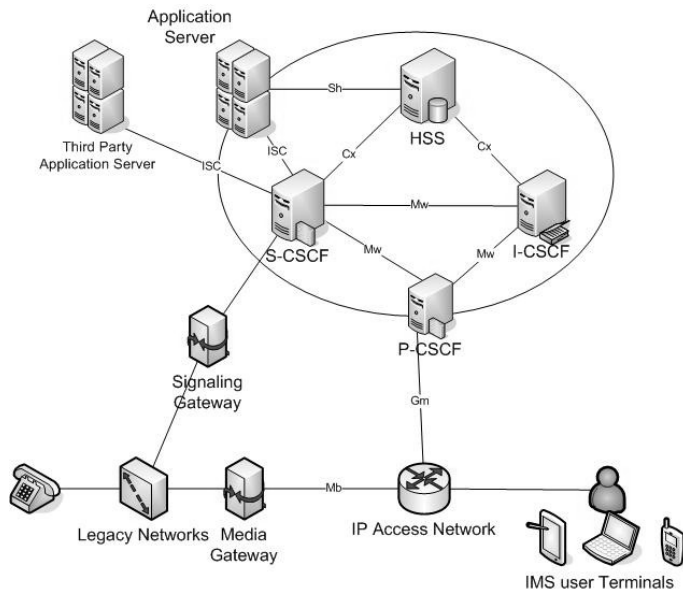

Fig. 1 Simplified IMS Architecture.

currently independent services, blending web and IMS/SIP applications, and providing the ability to define, provision, and support offers involving such converged applications. The general term for all of these functions is service brokering or service blending. This paper exposes various methods of service control in IMS as defined by the 3GPP, and investigating the advantage and shortcomings of each method, explaining the need of service brokering in the IMS platform. The paper introduces the work of 3GPP SA2 group studying the impact of service brokering in the IMS architecture, and addresses some of the issues left for further study.

The remainder of this paper is organized as follows. Section II reviews the related work, in particular the 3GPP specifications of service provisioning in IMS. Section III presents main methods of controlling service invocation in IMS, explains the need of a service broker in the architecture, and presenting its main roles. Section IV introduces the service brokering concept, explains the service broker tasks, and illustrates the Service broker position within the IMS architecture. Section IV addresses the main issues of integrating a service broker in IMS. Finally the paper is concluded in Section V.

II RELATED WORK

The IMS was defined from 3GPP Release 5 specifications as overlay architecture on top of the 3GPP Packet Switched (PS) Core Network for the provision of real time multimedia services [6]. The release 6 version of [6] added a new requirement to support access from networks other than GPRS. This is the so-called access independence of the IMS, since the IMS provides support for different access networks. Further enhancements have been added in Releases 7 and 8.

Recently the Open Service Architecture (OSA) was introduced for service creation. On the service side the target

was to stop standardizing new services and to concentrate on service capabilities [15]. OSA abstracts services from their realization using the concept of interfacing, which describes how interaction between parties will occur. The 3GPP extended the OSA specification in Release 7 [12] to include provision for a service broker. 3GPP [12] specifies that a service broker enables service selection, service provisioning, feature interaction, and service chaining.

The Service Broker architecture has been introduced to 3GPP IMS architecture in Release 8 [13]. The objective is to provide a coherent and consistent IP multimedia service experience when multiple applications are invoked. The work is handled by 3GPP SA2 (Architecture) group in [13]. So far, just some high level deployment scenarios, and some use cases have been defined.

The Open Mobile Alliance (OMA) is developing IMS application-enabler specifications and certifying the enabler with the Global Certification Forum (GCF) while providing conformance and interoperability test cases [14]. The OMA which defines an architecture named OMA Service Environment (OSE) in which one can take all advantage of the network is emerging in order to satisfy these requirements of the mobile industry. The key component of the OSE is the enabler called Policy Evaluation, Enforcement and Management (PEEM).

The FOKUS Fraunhofer Institute for Open Telecommunication Systems designed and implemented the OpenPEEM [16], which is an OMA compliant PEEM enabler, placed on top of the Parlay X gateway within the OpenIMS Playground at FOKUS. The PEEM enabler provides the core SOA principles: reuse, delegation, and composition. The OpenPEEM at FOKUS is situated on top of Parlay X Web Services. Policies are used to protect the Parlay X Web Services and also allowing Web Service orchestration [16].

III SERVICE CONTROL IN IMS

Service control in IMS takes place entirely on SIP ASs, as IMS Call Session Control Functions (CSCFs) components do not contain any service logic. Determining the sequence and invocation of applications running on the SIP ASs may be done by three methods:

- 1) The Serving-CSCF (Basic IMS Session Control): This is service blending using standard IMS core elements based on initial filter criteria (iFC) processing [5]. The iFCs stored in the Home subscriber Server (HSS) within the Subscriber Profile provides simple service logic to decide which AS shall be linked-in. When a session passes through the S-CSCF it checks whether any of the user's iFC match the session parameters, and forwards the request via the ISC interface to the AS indicated in the filter criteria. The AS performs the service logic.

Generally this method is fairly simple and easy to program, however it falls short when blended service logic requires more sophisticated interactions among applications. As it is up to the AS to decide whether to

remain on the signaling path for the whole session or not, by adding its address to the Record-Route SIP header or replacing it with another URI. Also ASs are unaware of the existence of other AS, and whether these will be included on the signaling path, since no service or session state can be passed between the ASs.

- 2) IMS Standard Service Capability Interaction Management (SCIM) [7]: 3GPP has introduced the SCIM as a function within the SIP application server domain of IMS for managing interactions between AS's. The SCIM allows more service-oriented orchestration and execution control on a SIP application-server level. It behaves as a specialized AS using SIP to communicate with an IMS S-CSCF and SIP-based application servers to coordinate applications within the context of IMS sessions. However the 3GPP standards provide a very high level definition of SCIM, a number of issues are not addressed in the standards, including: Is SCIM a standalone function, part of an AS, or part of the S-CSCF? Does it handle SIP services only? What kind of interaction management does it provide? Does it provide support for 3rd party services, or must the applications be trusted ones provided by the carrier?
- 3) Business Rules / Policy Driven Orchestration: Loose scripting can be done across web services applications by Business Process Execution Logic (BPEL) scripts in a Service Oriented Architecture (SOA) environment by adding Service Broker to the IMS architecture.

The Service Broker concept has emerged as a component that links different service types in a flexible way at service creation and execution time. The SB has two main tasks [17]:

- 1) Service Execution Orchestration: to ensure that different applications (i.e. Service Providers) can co-exist peacefully, and function collaboratively. This requires that application designers define appropriate interaction logic in advance of publishing their work.
- 2) Service Offering Coordination: this role includes a set of operation functions to appropriately package and offer blended services to users (i.e. Service Requestors).

Fig. 2 illustrates the relationship between the Service Broker, service providers (i.e applications servers), and service requesters (users or other applications servers). Service providers publish information describing the offered service at the SB using Web Services Description Language (WSDL) Specification. Service requesters query the service broker for the required service via a Universal Description, Discovery, and Integration (UDDI) interface. Service providers and requesters communicate with each other by Extensible Markup Language (XML) messages encapsulated in Simple Object Access Protocol (SOAP) envelopes that are transported by the HTTP protocol. Thus service providers can re-use and combine different basic services through coordinating service logic to invent a new application. And customers will be able

to choose among various service providers, which best suit their requirements and equipment's constraints.

The concept of service blending offer means to create new and interesting services economically by using existing service elements. Consequently it could highly impact the interoperability between services from various communication domains, and reduce cost and development time of introducing services to end customers.

Introducing the Service Broking concept in IMS has significant value beyond S-CSCF IFCs and the SCIM entity. Service Broker can utilize richer information in determining which application servers are invoked and how to deal with service blending. In addition, service broker support dynamic application interleaving. Fig 3. shows the position of the Service broker entity within the IMS architecture. The service broker is located between the S-CSCF at the session control layer and different types of application serves at the application layer.

IV SERVICE BROKING FUNCTION IN IMS

The concept of service brokering is the ability to package, provision, and supply a set of services to the application server implementing the business logic. The service broker function shall enable the delivery of multiple services in an operator network in a managed and controlled fashion. Therefore, whenever an event occurs, there is a need to ensure that the set of applications or services that may act on that event are invoked in a manner that does not conflict with any other application or service defined in the provisioned package of services.

In 3GPP specification [13], the service broker architecture is described, along with notes of required enhancements and further studying issues. In this section we address some of the main issues noted in the 3GPP specification:

- The service broker can be implemented as a standalone component or collocated with the AS or the S-CSCF. In the latter case the interface between it and the HSS will be the same as the component the SB exists with, however in the former case the interface to be used is not defined in the standards yet. We propose using the

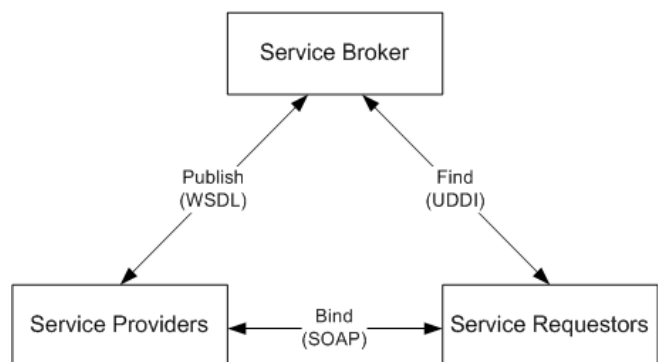

Fig. 2. SOA main players.

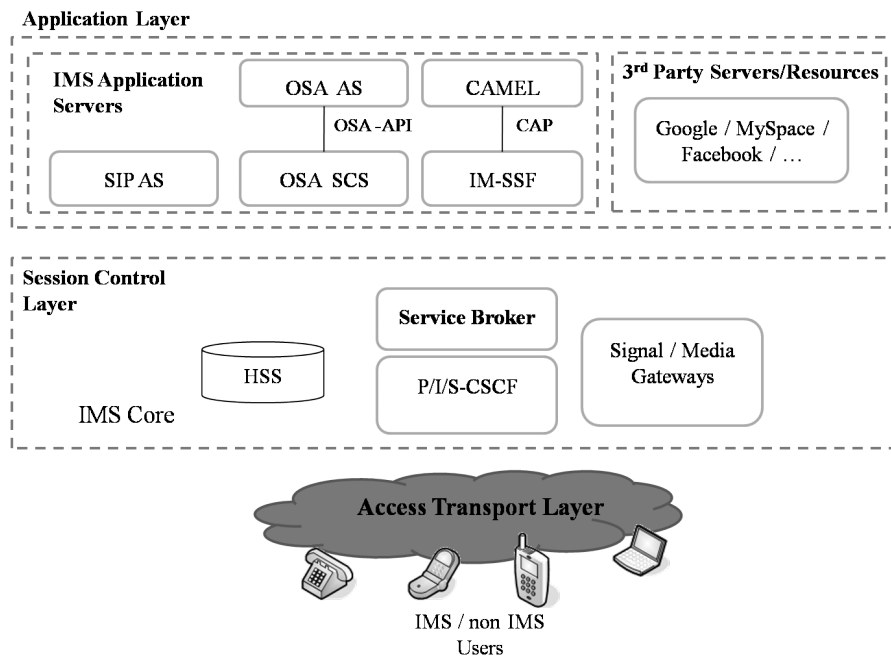

Fig. 3. The Service broker entity in the IMS architecture.

Sh interface [11] between the SB and the HSS. The Sh interface commands can provide the required exchange of the interaction logic stored in the HSS as part of the user profile. Fig. 4 describes the interfaces between the service broker and other entities of the IMS architecture.

- Interaction logic is expressed as a set of rules based on service invocation history for each user. The SB use this information to provide dynamic chaining of the IMS services at the run time based on service invocation history. We propose that the SB can be used to provide the same function to the application servers'

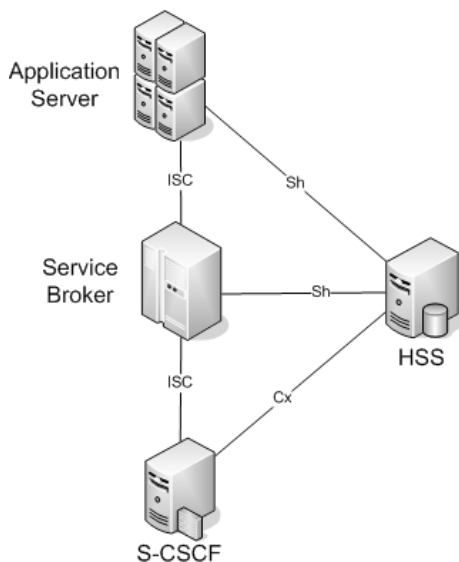

Fig. 4. Service Broker interfaces with other IMS components.

behalf; enabling service blending in a SOA environment, where some service applications may act as a user and re-used other services. In this case it is also required to download the interaction logic of the application server intended to provide an innovated service using a combination of other services. The Sh interface can be used to interchange this information between the AS and HSS, Fig. 5 illustrated the IMS service profile including the interaction logic entity.

- The ISC interfaces require enhancement to carry IMS service invocation history that is expressed as a list of (Service ID, Service Effect). As a SIP based interface [8], the ISC interface can be easily extended to provide the required enhancements.
- The Service Broker Function be centralized on a single Service Broker, distribute, or hybrid and maybe reside on a separation physical entity or collocate with other function entities (S-CFCF or Application Server).
- As the service broker is the controller and composer of service provisioning, we argue that a common Service Level Agreement (SLA) between the IMS domain and service providers as a necessity.

CONCLUSIONS AND FURTHER WORK

This paper has presented our research work on service provisioning and blending within IMS framework. The limitations of the current standards defined by the 3GPP were discussed, particularly regarding entities in charge of service control. In this paper, we address the integration of a Service broker entity into the IMS architecture. The objective is to provide a coherent and consistent IP multimedia service

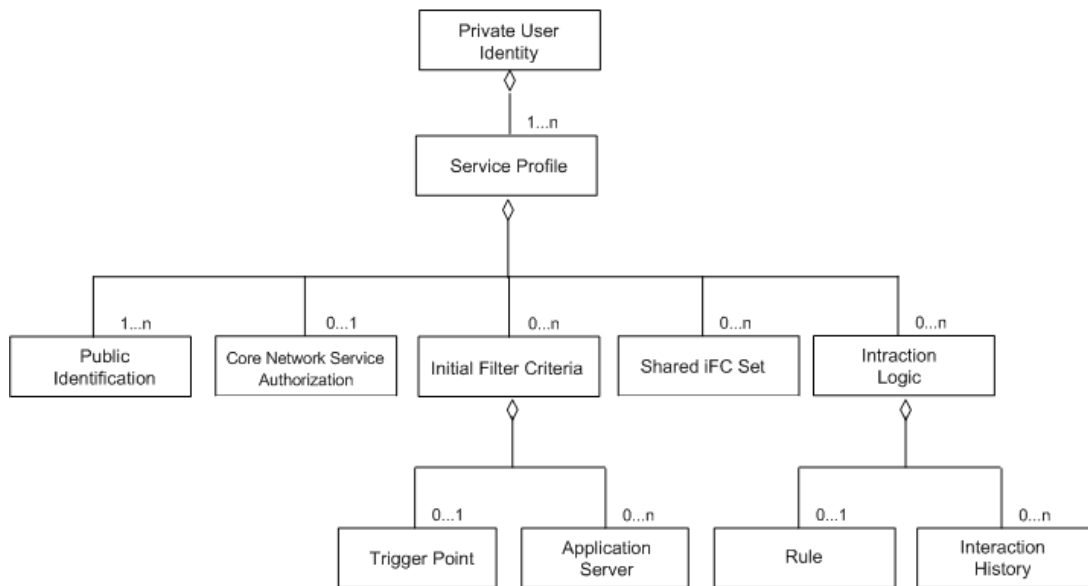

Fig. 5. IMS Service profile including the proposed Interaction logic entity.

experience when multiple applications are invoked. Service broking concept offers benefits to all stakeholders

SOA describes a computing model that supports the real-time assembly and orchestration of loosely coupled, stateless, reusable, services into complex, enterprise processes.

With the initial Filter Criteria method, only a static order of chaining these applications is possible. The Service Broker, via the service invocation history in the ISC and rule-based interaction logic provisioned offline, can provide additional function of dynamically chaining the IMS services at the run time based on service invocation history. We are in the process of developing a service broker that address the issues previously discussed in this paper. This service broker will be a part of our IMS-testbed, built based on the OpenIMS core [18].

REFERENCES

- [1] "Definition of Next Generation Network ", available online at http://www.itu.int/ITU-T/studygroups/com13/ngn2004/working_definition.html
- [2] M. Rodriguez, and J. Gabeiras, "Bridging the Standardization Gap to Provide QoS in Current NGN Architectures," IEEE Communications Magazine, October 2008, pp: 132-137.
- [3] T. Magedanz, N. Blum, and S. Dutkowski, " Evolution of SOA Concepts in Telecommunications," IEEE Computer Magazine, November 2007
- [4] D. Menasce, V. Dubey, "Utility-based QoS Brokering in Service Oriented Architectures," IEEE ICWS 2007.
- [5] M. Unmehope, K. Vemuri, A. Bennett, "Parlay/OSA from Standards to Reality," 2006 , Wiley & Sons.
- [6] 3GPP TS 23.228, "IP Multimedia Subsystem (stage 2)," 2006.
- [7] 3GPP TS 23.002, "Network architecture,"
- [8] 3GPP TS 24.228,"Signalling flows for the IP multimedia call control based on Session Initiation Protocol (SIP) and Session Description Protocol (SDP); Stage 3," 2005.
- [9] 3GPP TS 23.207, "End-to-End QoS Concept and Architecture," 2005.
- [10] 3GPP TS 29.208, "End-to-end Quality of Service (QoS) signalling flows,"

- [11] 3GPP TS 29.329, "Sh interface based on the Diameter protocol; Protocol details," 2008.
- [12] 3GPP TS 22.127, "Service requirement for the Open Services Access (OSA); Stage 1,"
- [13] 3GPP TR 23.810 V0.5.0 (2007-05); Technical Specification Group Services and System Aspects; Study on Architecture Impacts of Service Brokering; Release 8; 3rd Generation Partnership Project, May 2007.
- [14] Enabler Release Definition for IMS in OMA, Open Mobile Alliance, OMA-ERELD-IMSinOMA-V1 0-20050809- A, August 2005
- [15] Miikka Poikselka, Georg Mayer, "The IMS IP Multimedia Concepts and Services", John Wiley, 3rd edition 2009.
- [16] T. Magedanz, S. Dutkowski, Y. Gerat Gil-Laich, "The OpenPEEM as core for service orchestration within the Open IMS Playground at FOKUS," ICIN 2007, Oct 2007
- [17] Niklas Blum, Thomas Magedanz, Florian Schreiner, "Definition of A Service Delivery Platform For Service Exposure And Service Orchestration in Next Generation Networks," Ubiquitous Computing and Communication Journal, Volume 3 No. 3, July 2008
- [18] FOKUS Open Source IMS project, <http://www.openimscore.org>

BIOGRAPHIES

Asma Elmangosh received her B.Sc. Eng. (Hons) degree from the Higher Institute of Industry in 1998, and received her MSc in 2007 from the same institute. She is currently holding an assistant lecturer position at the same institution. Her research interests include next generation resource management, and service provisioning in heterogeneous networks.